

CAD FILE:

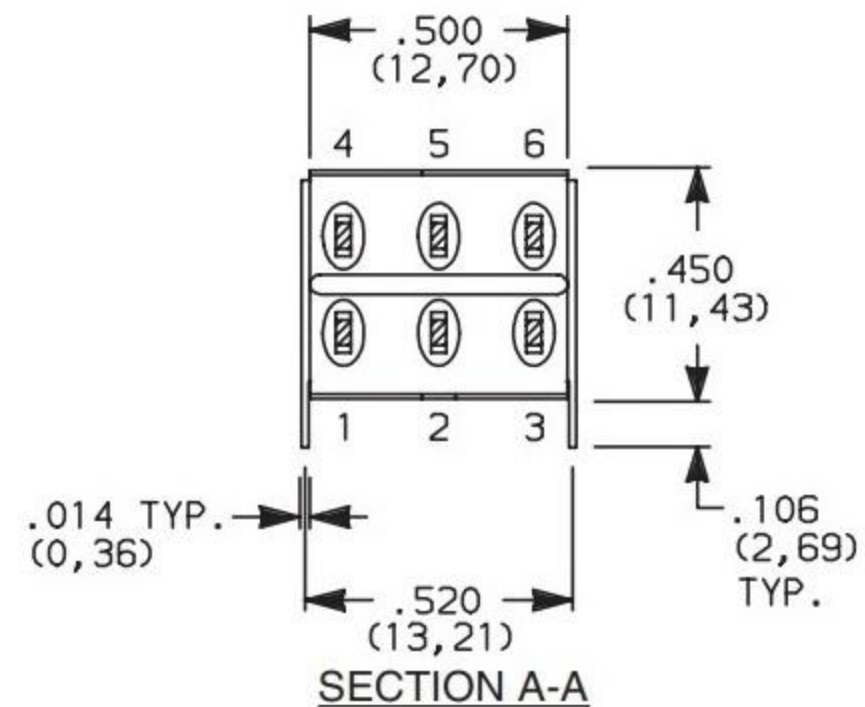
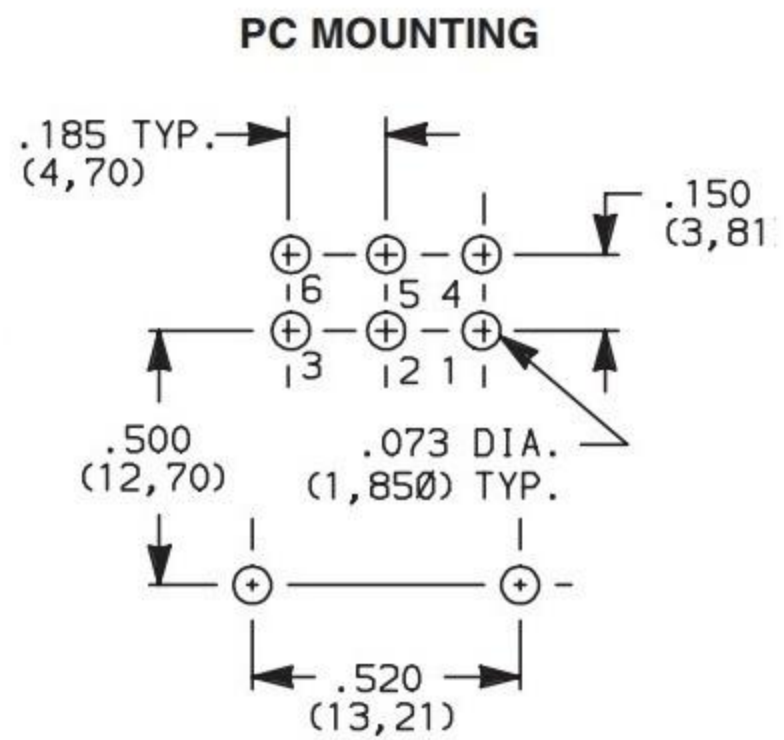
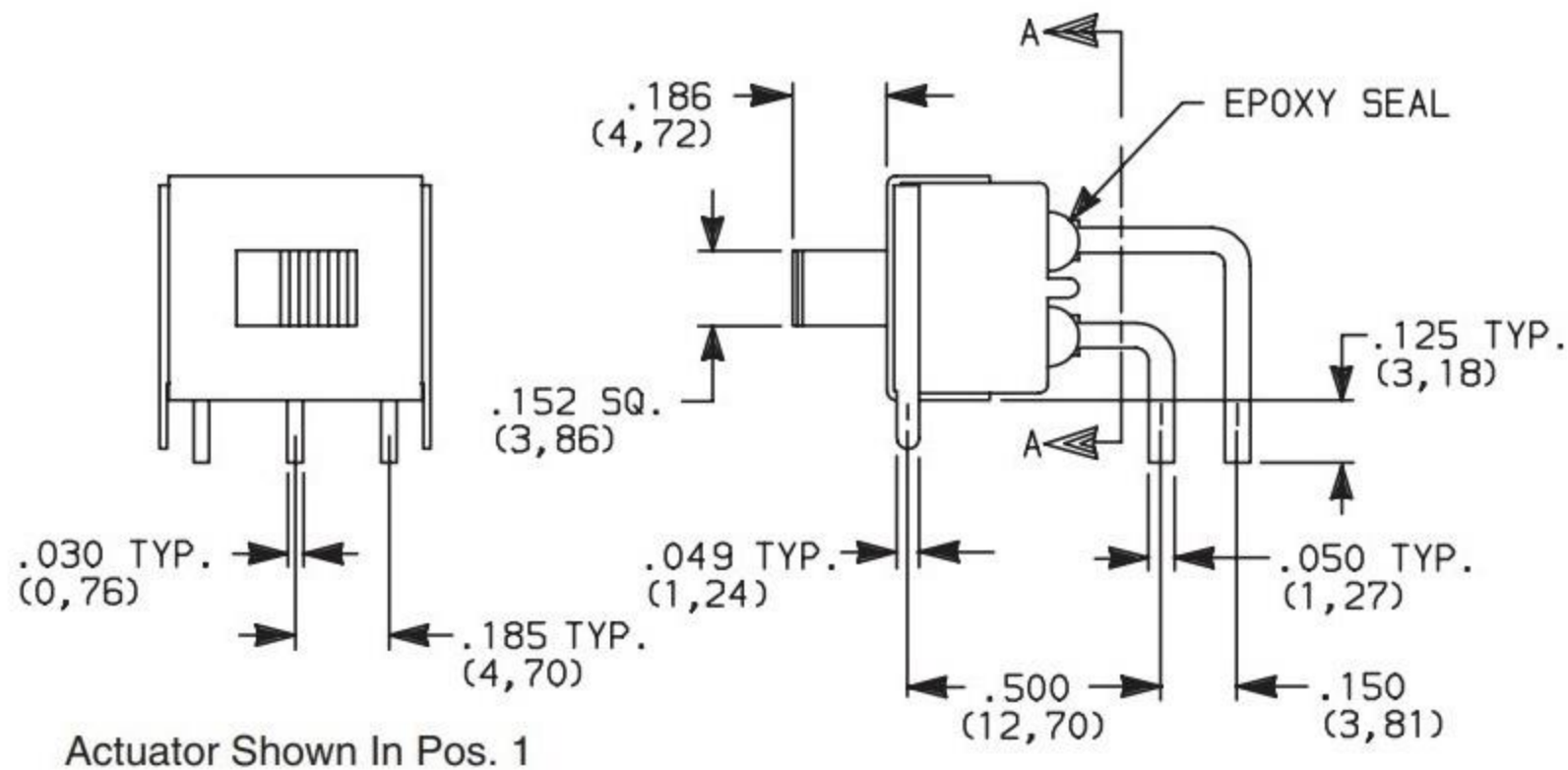

注: "\*"表示关键尺寸(4个)

- 拨动开关立式技术参数:
1. 额定负荷: AC 125V 2A 3A
  2. 接触阻抗:  $\leq 50m\Omega$
  3. 绝缘阻抗:  $\geq 100m\Omega$  DC500V
  4. 耐焊温度:  $250 \pm 5^\circ$  5s
  5. 使用寿命: 10,000 cycles
  6. 使用温度:  $-25^\circ\text{C}$  to  $80^\circ\text{C}$
  7. 使用湿度:  $\leq 85\%$  RH
  8. 操作力: 160gf 256gf 300gf 可定制
  9. 手柄长度: 2mm-10mm 可定制

NO.	PARTS	MATERIALS	Q'TY	FINISH	TOLERANCE UNLESS SPECIFIED	ISSUE	DATE	DESCRIPTIONS OF REVISION	APPD.
8									
7	STEEL BALL	STEEL	1	NATURAL					
6	SPRING	STEEL WIRE	1	NATURAL					
5	CONTACT CLIP	PBS STRIP	2	Ag PLATED					
4	TERMINAL	BRASS STRIP	8	Ag PLATED					
3	BASE	PHENOLIC RESIN	1	NATURAL					
2	FRAME	STEEL STRIP	1	Ni PLATED					
1	KNOB	POM	1	BLACK					
					TITLE : VERTICAL SLIDE SWITCH		UNIT : mm	DRWG NO.:	
					MODEL:		SCALE: 3:1	DWN.	2012-10-26
					东莞市高迪电子有限公司		CHK'D		2012-10-26
							APPD.		